

# GASO.LINE

Aussi disponible  
GAS50031K Tracteur Allis Chalmers

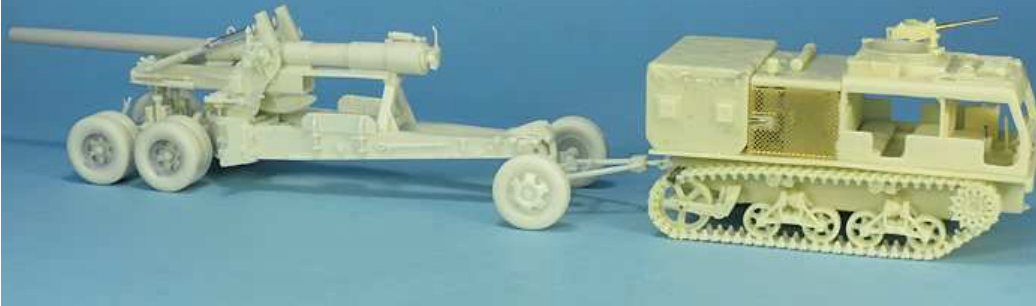

## canon US 155mm M1A1 Long Tom

### CARACTERISTIQUES TECHNIQUES

Le canon de 155mm, connu sous le nom de Long Tom, est un canon de 155mm utilisé par l'armée américaine durant la seconde guerre mondiale et la guerre de Corée. Conçu dans les années 1930, pour répondre aux besoins des États-Unis dans le domaine de l'artillerie lourde, il fut utilisé comme canon de campagne lourde standard, à partir de 1938, mais aussi comme batterie côtière, pour la défense des côtes américaines. Il peut tirer un obus de 45.36 Kg et a une portée maximale de 22.01 Km. Un petit nombre de Long Tom ont été prêtés au Royaume-Uni (184) et à la France (25).

### TECHNICAL CHARACTERISTICS

The 155mm cannon, known as the Long Tom, is a 155mm gun used by the US Army during World War II and the Korean War. Designed in the 1930s, to meet the needs of the United States in the field of heavy artillery, it was used as a standard heavy field gun, from 1938, but also as a coastal battery, to defend the American coast. It can shoot a shell of 45.36 kg and has a maximum range of 22.01 Km. A small number of Long Tom was lent in the UK (184) and France (25).

Ce modèle est fabriqué par **Gaso.line**  
10, passage du charolais 75012 Paris France  
Tél./Phone: (33) 01.44.75.01.61  
E-mail: [info@quarter-kit.com](mailto:info@quarter-kit.com) Web site: [www.quarter-kit.com](http://www.quarter-kit.com)

GAS50256K 155mm Long Tom			30	Suspensions	2
N°	Désignation	Qt	31	Triangle remorque	1
1	Flèche G	1	32	Roue remorque	2
2	Flèche D	1	33	Enjoliveur roue remorque	2
3	Chaise de route culasse	1	34	Support attelage	1
4	Bêche arrière	2	35	Support	1
5	Support chaise de route	2	36	Affut canon	1
6	Bavette Flèche G	1	37	Canon	1
7	Bavette flèche D	1	38	Glissière canon	1
8	Bêche flèche	2	39	Arceau	1
9	Tige laiton Ø 0.5 x 5mm		40	Vérin canon G et D	1+1
10	Embase canon	1	41	Vérin A	1
11	Berceau canon	1	42	Vérin B	1
12	Levier A	1	43	Vérin culasse fermé	1
13	Crochets	4	44	Vérin culasse ouvert	1
14	Optique	1	45	Levier culasse	1
15	Volants	2	46	Bague canon	1
16	Boite de transfert	1	47	Culasse	1
17	Transmission	1	48	Embout vérin	2
18	Visueur	1	49	Canon	1
19	Patte vérin	4	50	Tube alu Ø 3 x 35 mm	
20	Crochet de remorquage	1	51	Tige plastique Ø 1 x 30mm	
21	Chaise de route canon	1	52	Tige plastique Ø 1.5 x 5 mm	
22	Roue	8	53	Tige laiton Ø 1 x 30 mm	
23	Jantes	4	Pièces spécifiques pour position de tir Parts for firing position		
24	Flasque jante	4			
25	Système levage route	1			
26	Système levage tir	1			
27	Etrier système levage	1			
28	Support suspension avant	1			
29	Support suspension arrière	1			
Si vous avez des pièces défectueuses ou manquantes, n'hésitez pas à nous contacter. If you have faulty or missing parts, don't hesitate to contact us.					

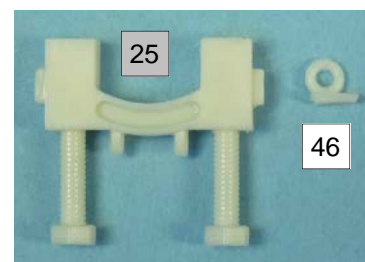
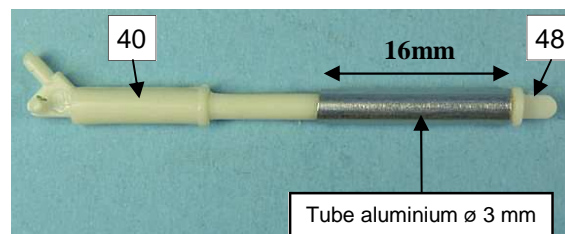
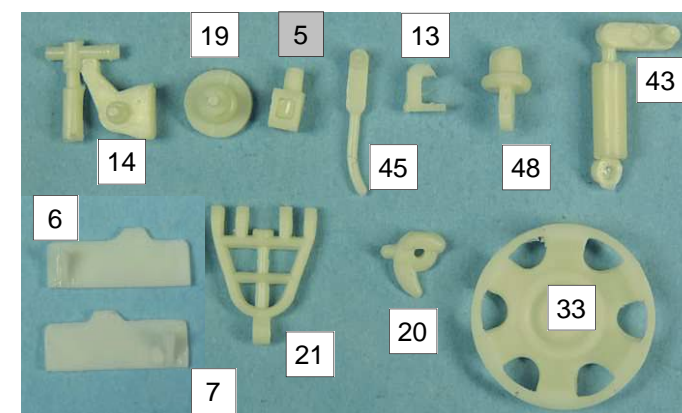
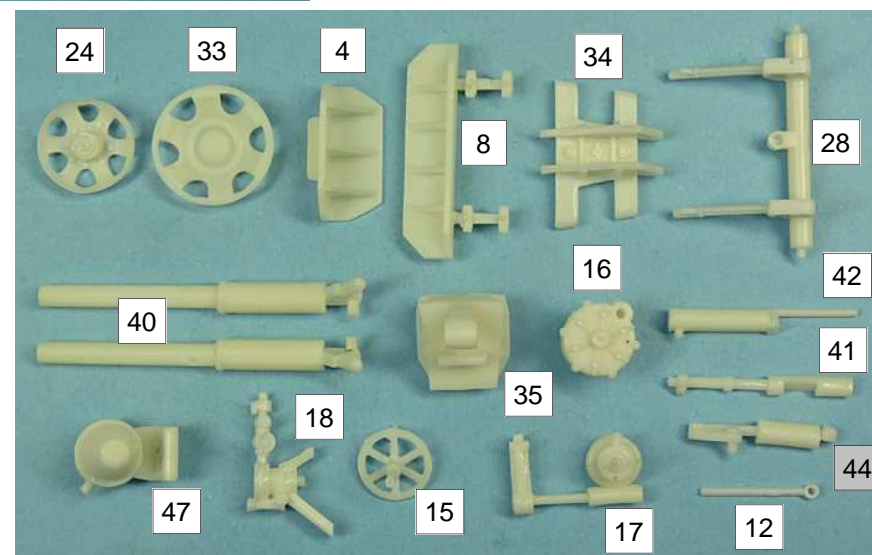
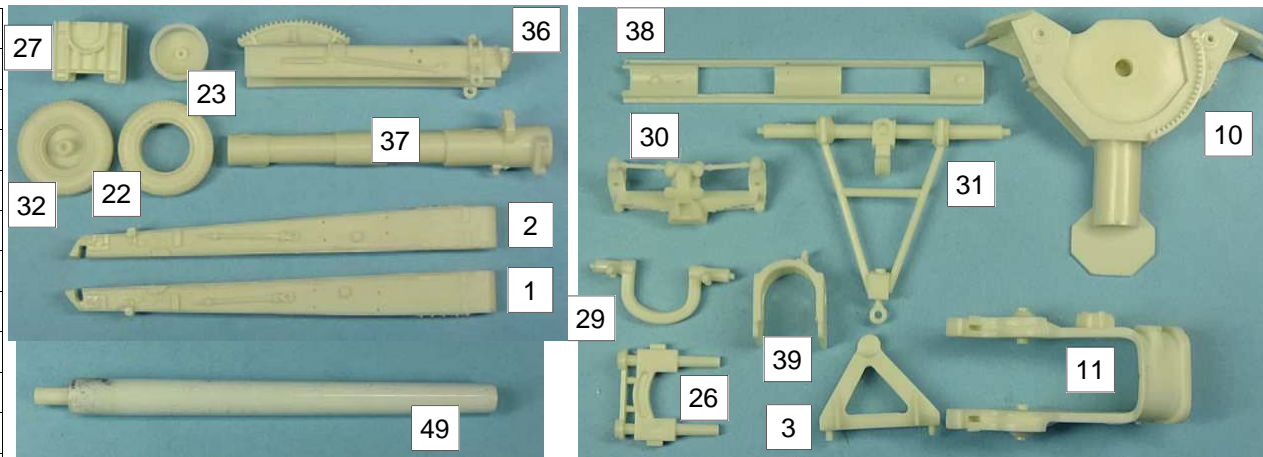

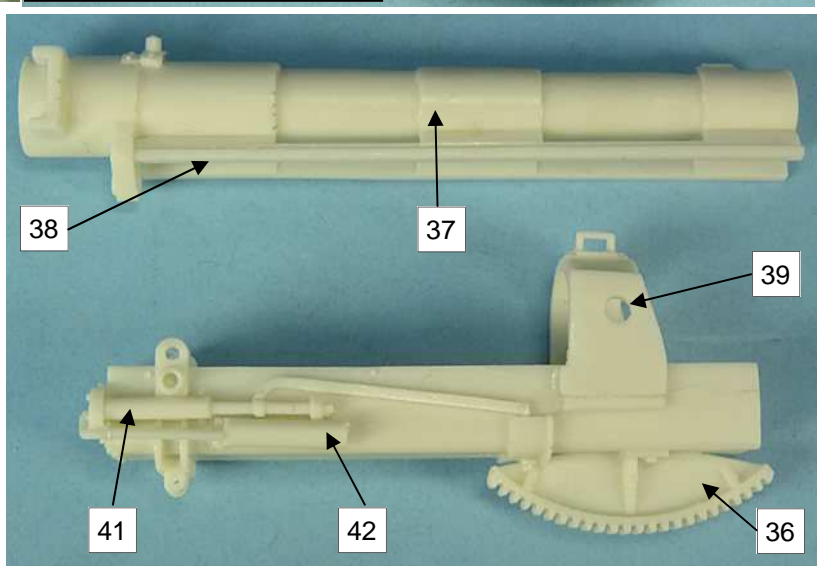
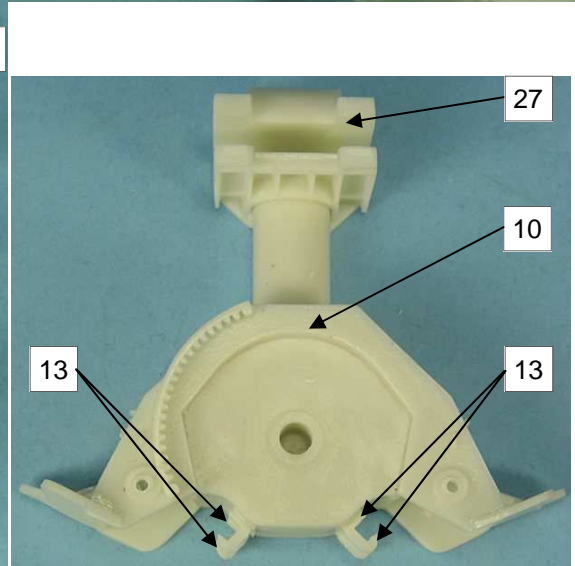
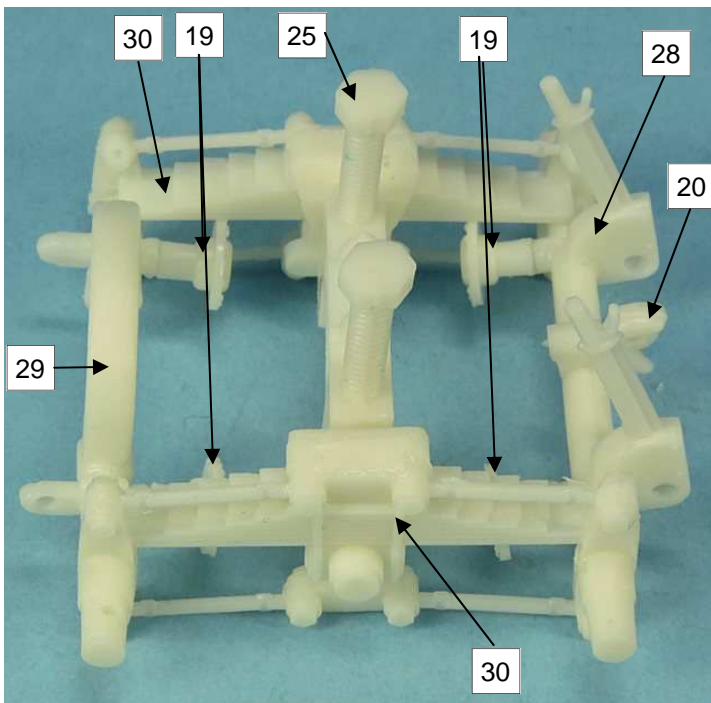
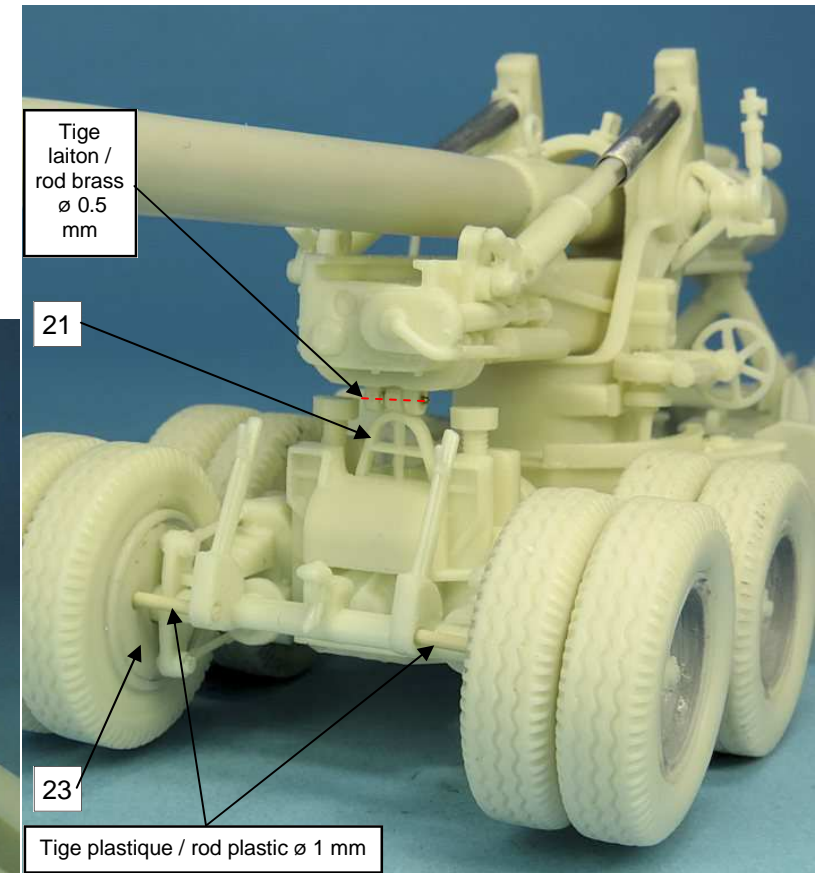
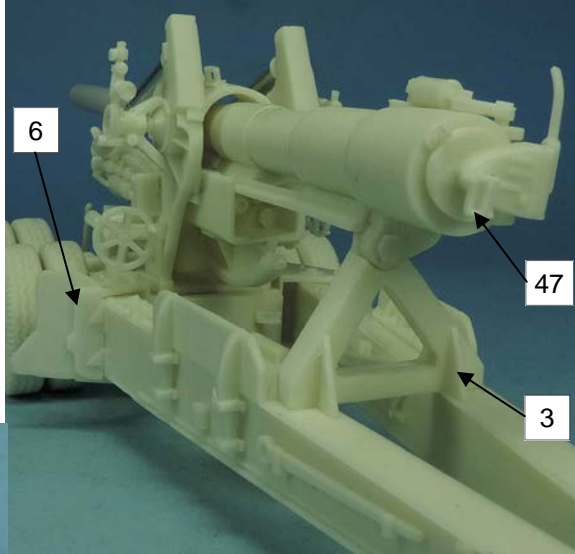
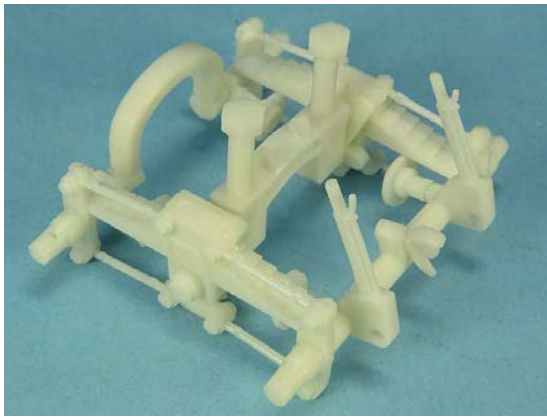
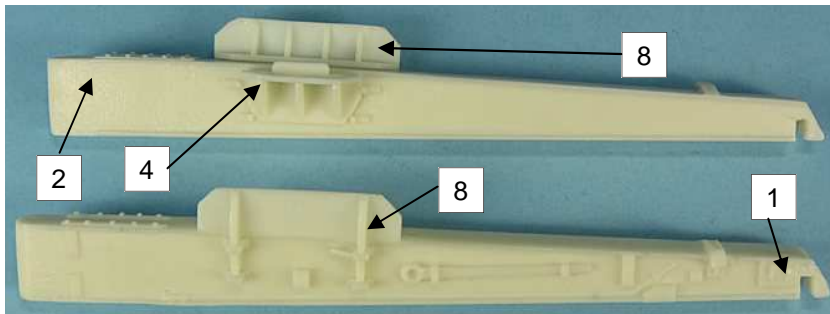

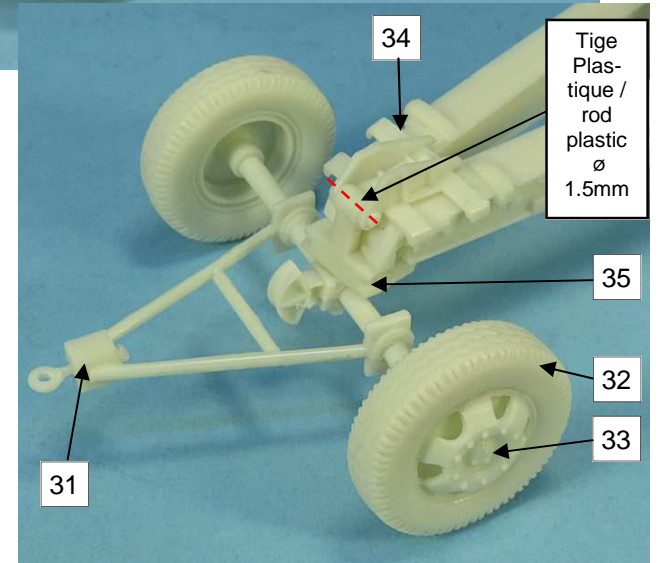
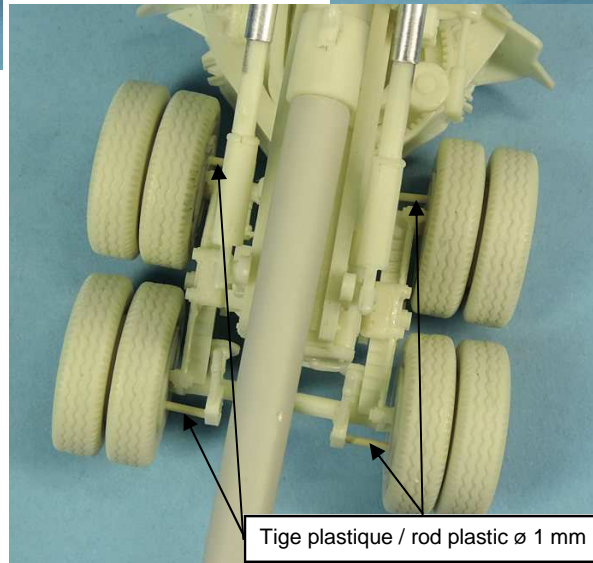
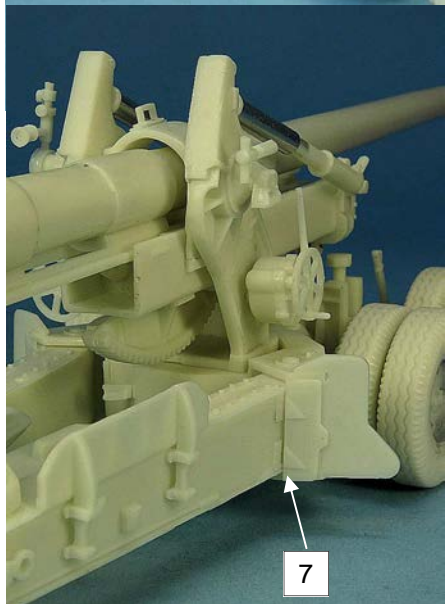
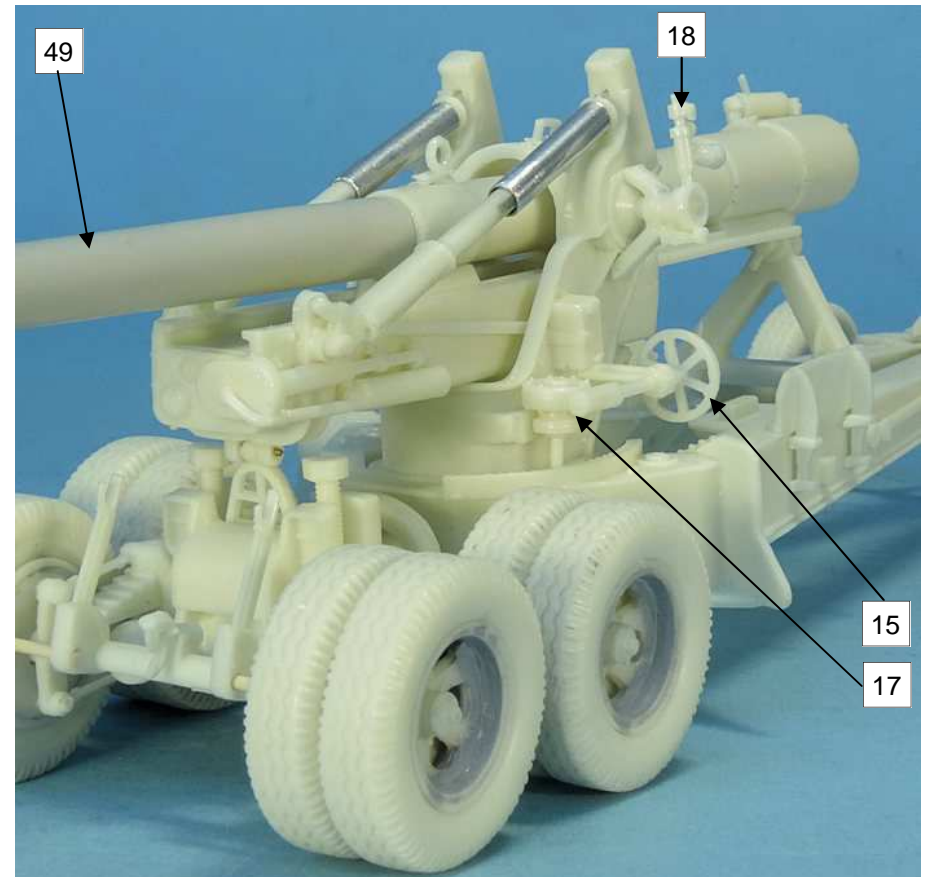
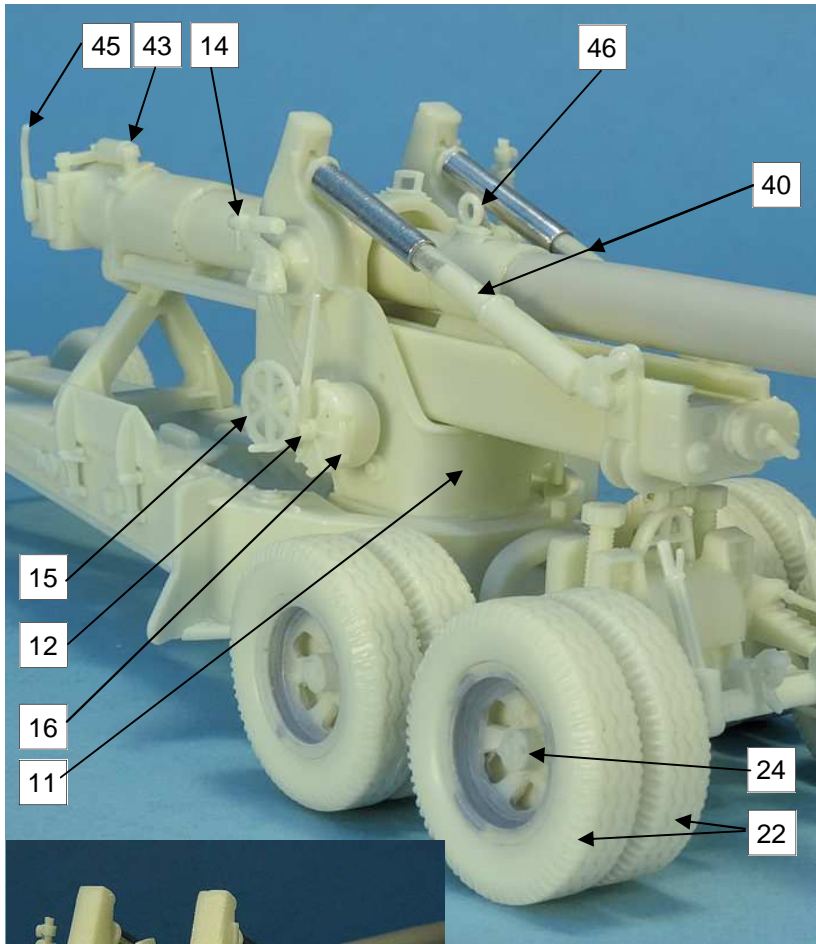

# Spécificités Position de tir

