

# GASO.LINE

## Semi-chenillé lance-roquette Schwerer Wehrmachtsschlepper

### CARACTERISTIQUES TECHNIQUES

250 des 825 « Schwerer Wehrmachtsschlepper » produits par Büssing-NAG et Ringhoffer-Tatra de décembre 1943 à mars 1945 furent dotés de cabines blindées (16 mm maxi). Cet engin de 13,5 tonnes était équipé du moteur essence 6 cylindres Maybach HL42 TRKMS de 4,2 litres, qui donnait 100 cv. Les performances étaient de 28 km/h et 300 km d'autonomie.

Le projet de remplacement de l'Opel Maultier blindé par la version Nebelwerfer du s.WS est envisagée rapidement, mais le faible nombre de s.WS disponible empêche une production en série de cette version et le l'Opel Maultier 15 cm Panzerwerfer 42 reste en production jusqu'à la fin de la guerre.

Les circonstances du moment imposèrent aux décideurs allemands d'opter pour des matériels plus simples et rapides à produire, ainsi, ce s.WS 15cm Panzerwerfer 42 illustre cette contrainte de fin d'empire.

### TECHNICAL CHARACTERISTICS

From December 1943 to March 1945, 825 "Schwerer Wehrmachtsschlepper" were manufactured by Büssing-NAG and Ringhoffer-Tatra. 250 sWS were fitted with an armoured cabin (max: 16 mm). The 13.5 tonnes sWS had one 4.2 litres, 6-cylinders HL42 TRKMS Maybach motor that yielded 100 hp allowing a top speed of 28 km/h, the range was 300 km.

The replacement project of the armored Opel Maultier by the Nebelwerfer version of the s.WS is considered quickly, but the weak number of available s.WS prevents a production in series of this version and the Opel Maultier 15 cm Panzerwerfer 42 remains in production until the end of the war.

This AA sWS illustrates the end of WWII constraints faced by the German decision-makers: the vital need to produce more simple stop-gap materiel dictated by that time circumstances.



Ce modèle est fabriqué par **Quarter Kit Modèle Shop**  
10, passage du charolais 75012 Paris France  
Tél./Phone: (33) 01.44.75.01.61 Fax: (33) 01.44.75.01.16  
E-mail: [info@quarter-kit.com](mailto:info@quarter-kit.com) Web site: [www.quarter-kit.com](http://www.quarter-kit.com)

Nomenclature GAS50201 s.WS Nebelwerfer		
N°	Désignation	Quantité
1	Châssis	1
2	Caisse arrière	1
3	Plancher cabine	1
4	Cabine blindée	1
5	Plaque avant blindée	1
6	Cloison	1
7	Blindage caisse arrière	1
8	Tourelle	1
9	Frein de parc	1
10	Attache de direction n°1	1
11	Attache de direction n°2	1
12	Attache de remorquage	1
13	Lance roquette	1
14	Tableau de bord	1
15	Volant	1
16	Siège	2
17	Barre de direction inférieure	1
18	Attache avant	1
19	Triangle de direction	1
20	Renvoi de suspension	2
21	Porte arrière D+G	2
22	Phare	1
23	Échappement	1
24	Trappe caisse arrière D+G	4
25	Barre direction supérieure	1
26	Pelle	1
27	Pioche	1
28	Hache	1
29	Bloc suspension pont avant	1
30	Trappe cabine	2
31	Rack obus A	4
32	Rack obus B	4
33	Rack obus C	4
34	Transmission cabestan	1

35	Boite de transfère	1
36	Raidisseurs	4
37	Cabestan	1
38	Barbotin	2
39	Intérieur barbotin	2
40	Flasque extérieur	6
41A	Galet central ext.	4
41B	Galet central int.	4
42	Flasque intérieur	6
43	Roue tendeuse	2
44	Roue avant	2
45	Section chenille	24
46	Blindage pont avant	1
47	Support volant	1
48	Volant A	1
49	Volant B	1
50	Bloc de réglage	1
51	Fusée 15cm	10
52	Bras de réglage	1
53	Molette	1
54	Plot d'antenne	1
55	Bouchon	1
56	Marche pied arrière	1
57	Phare Notek	1
58	Catadioptre arrière	1
59	Crochet arrière	1
60	Feux arrière	1
61	Tige laiton ø 0.7 x 10mm	1
62	Fil cuivre ø 0.3 x 100 mm	1
63	Ficelle x 50 mm	1

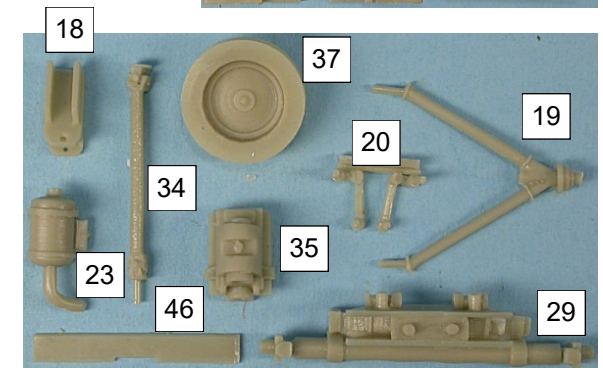
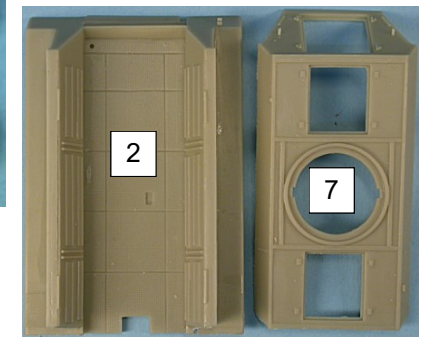
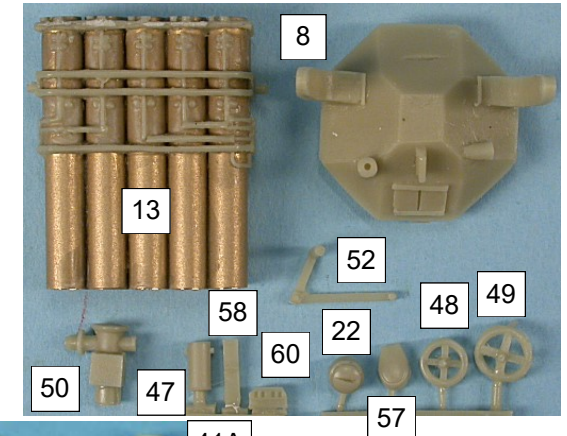
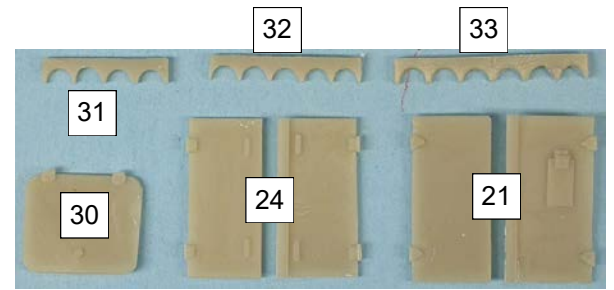
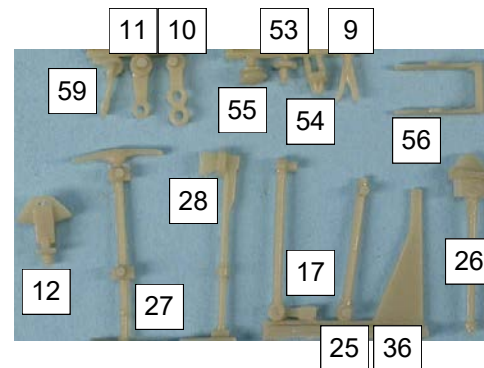
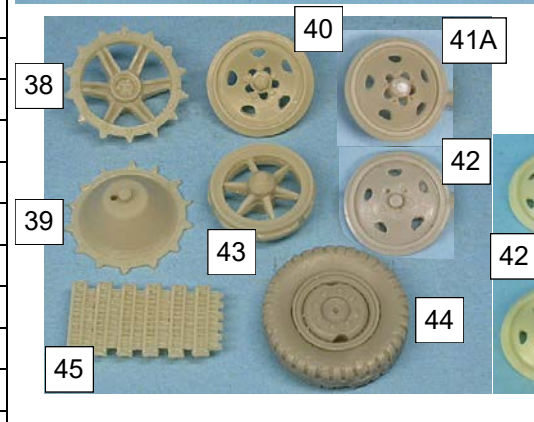
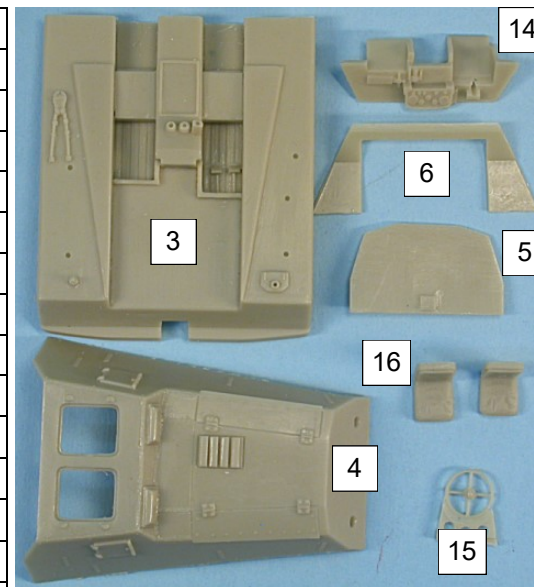



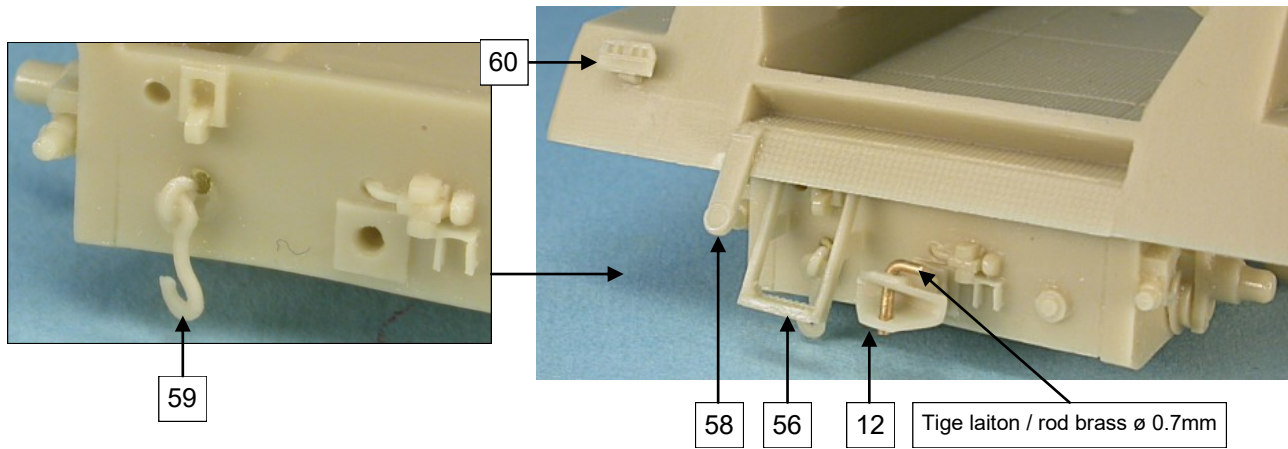
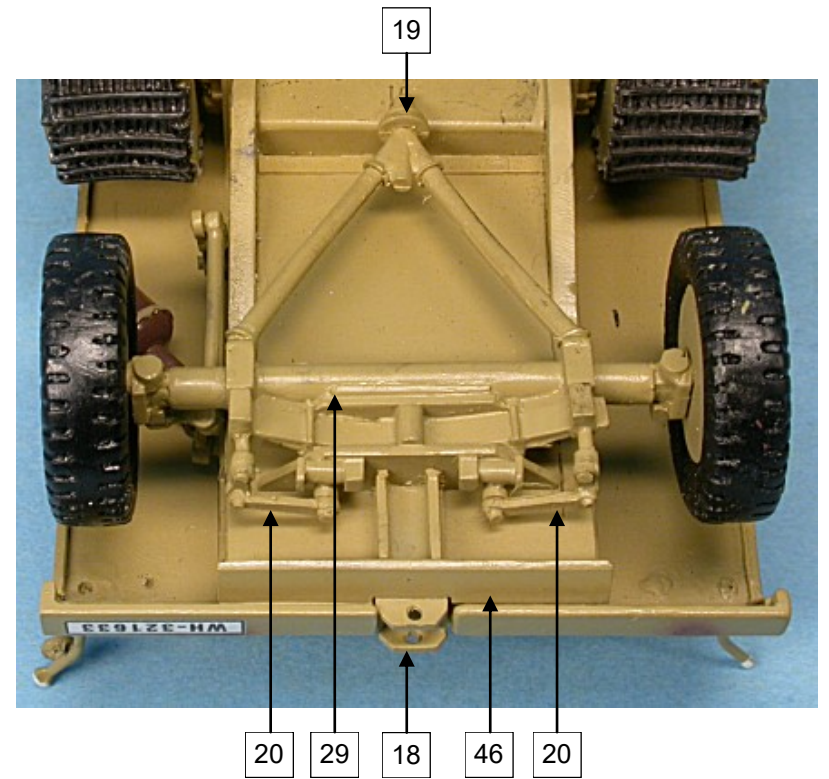
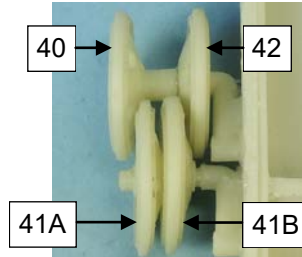
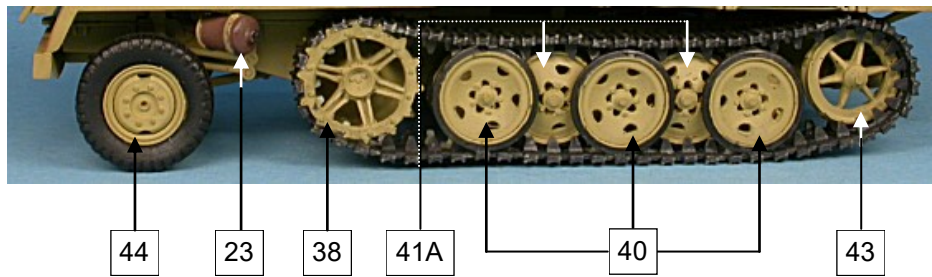
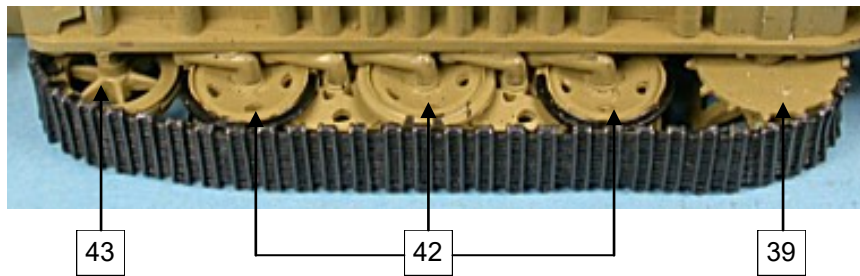
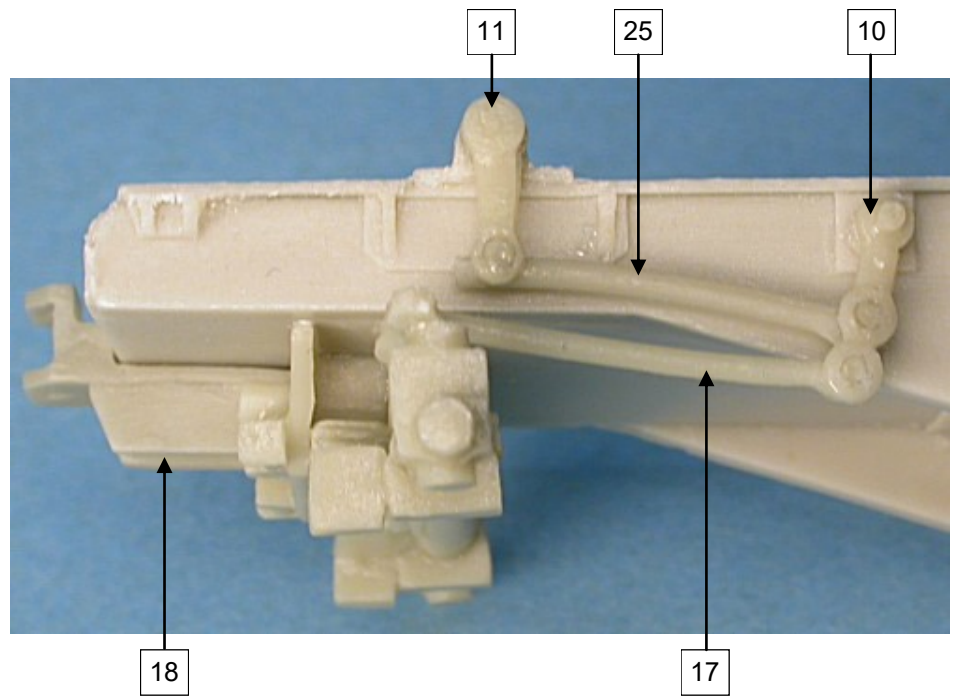
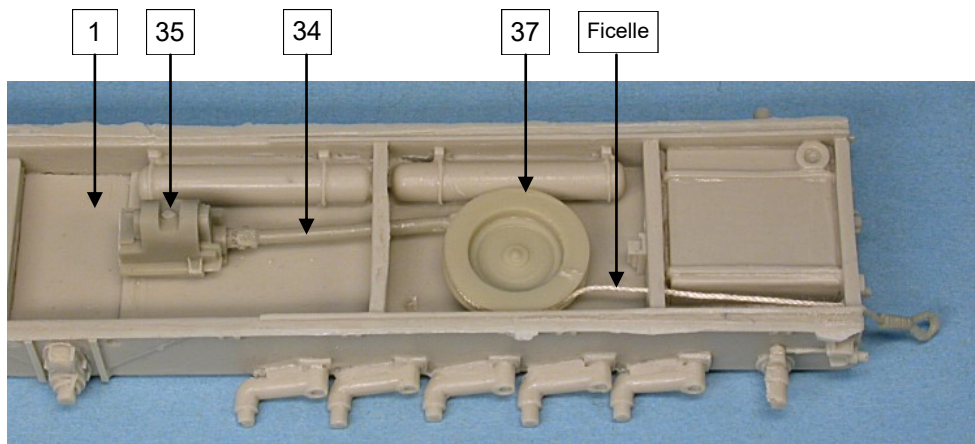



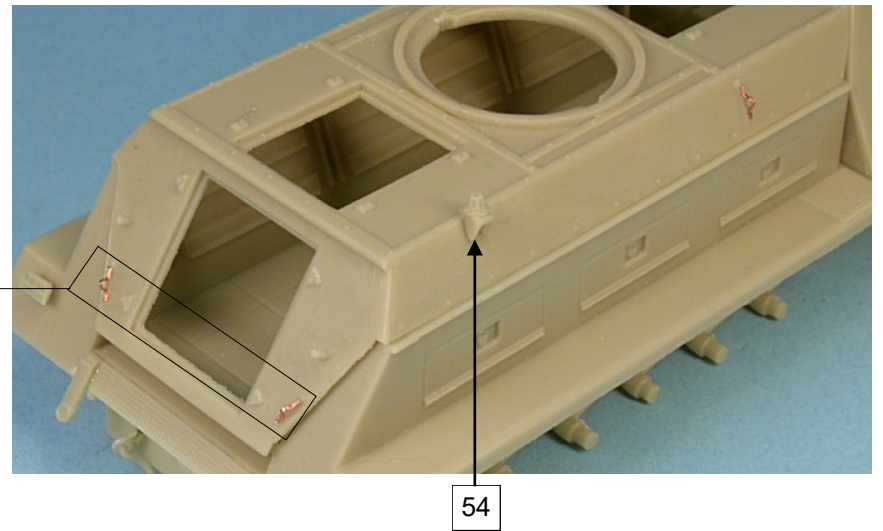
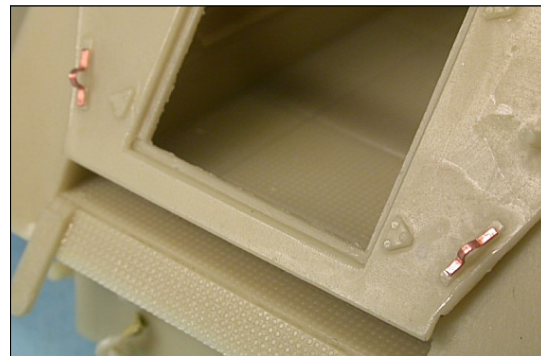
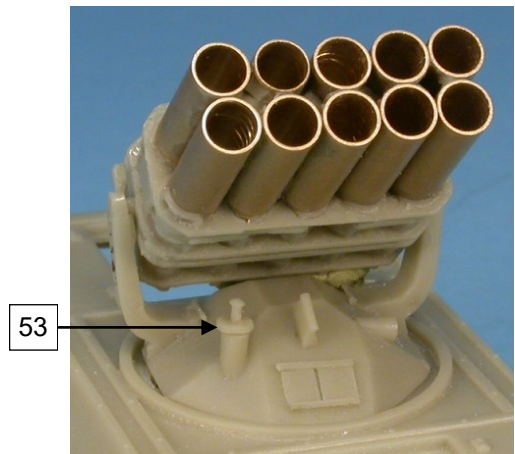
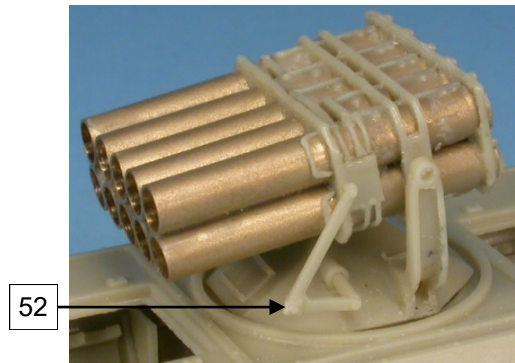
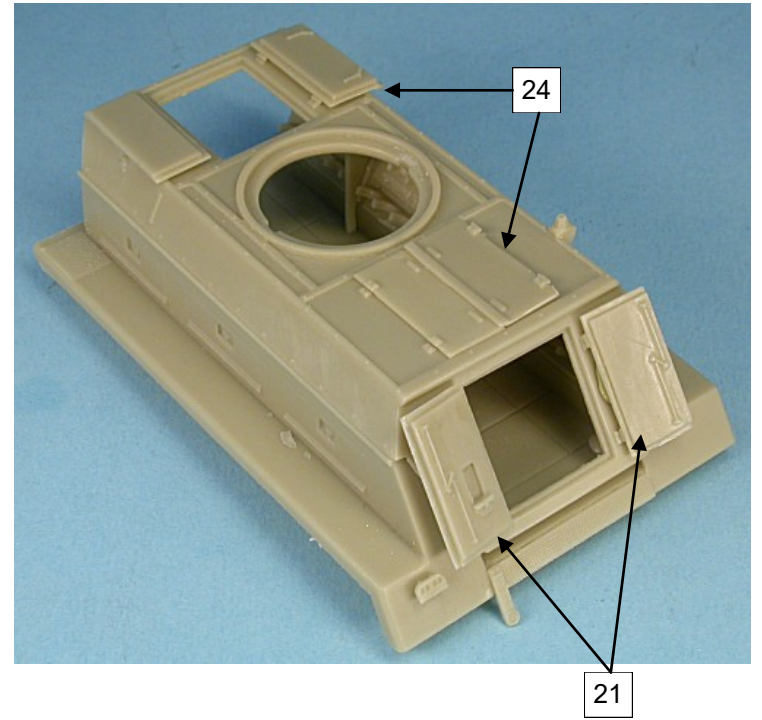
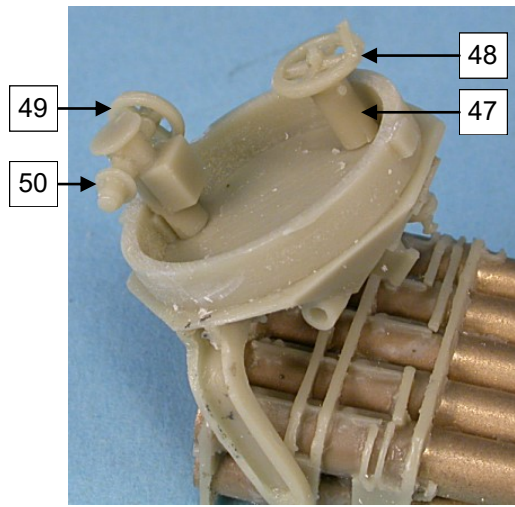



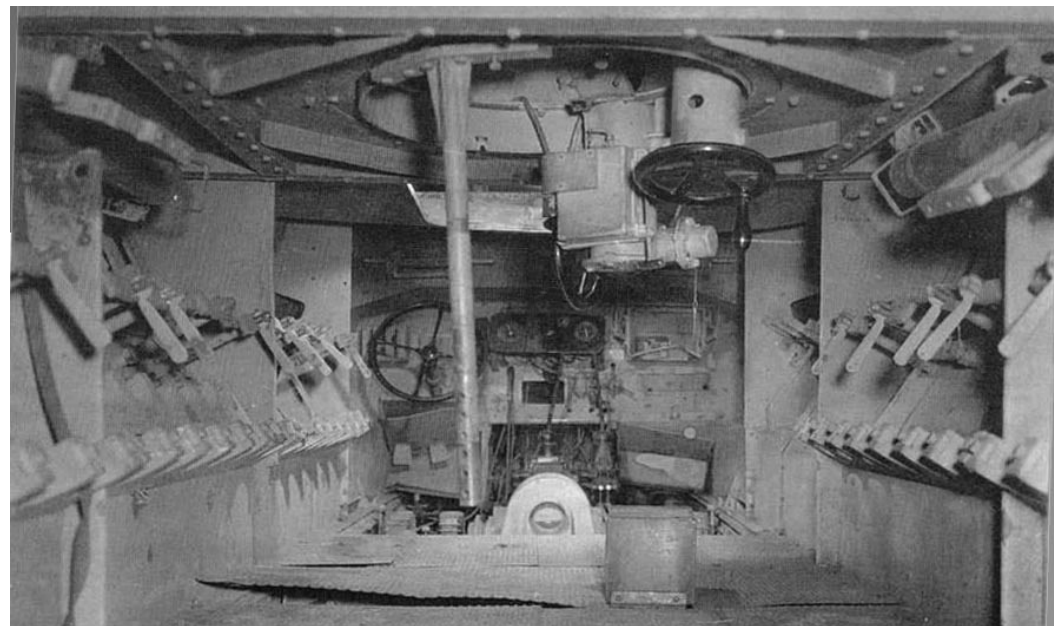
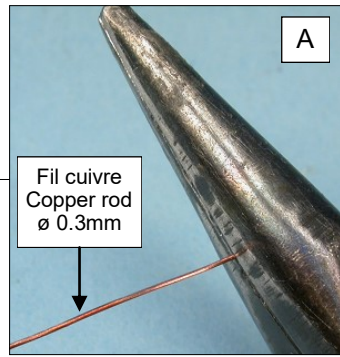
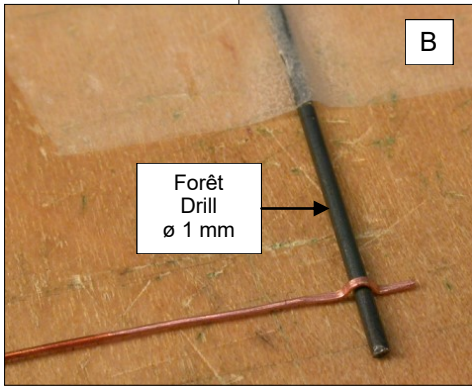
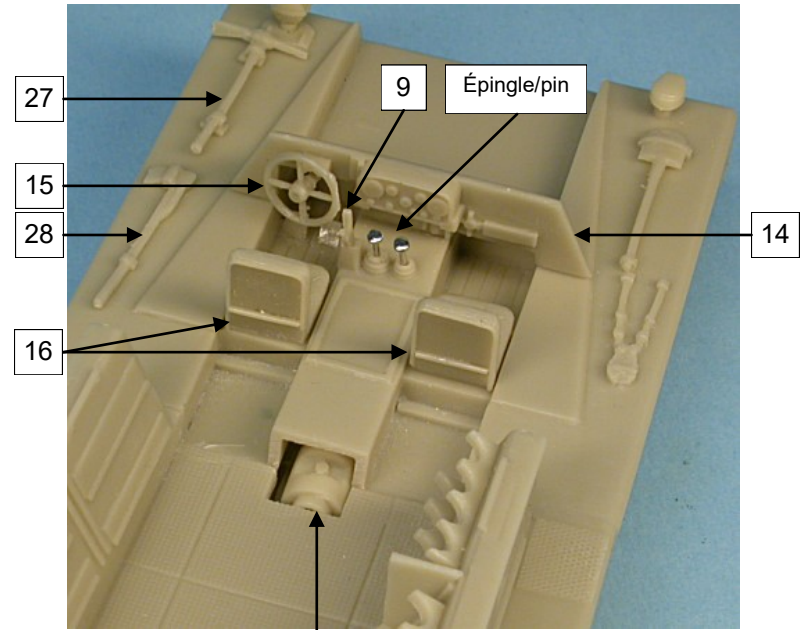
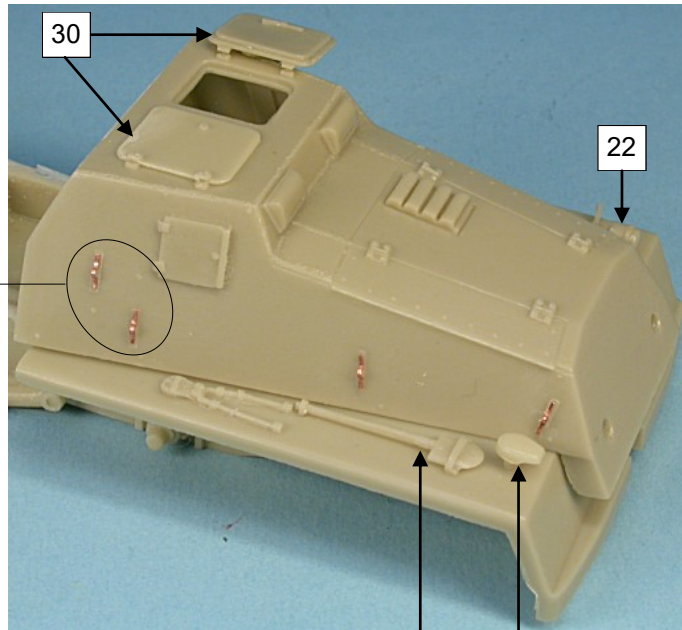
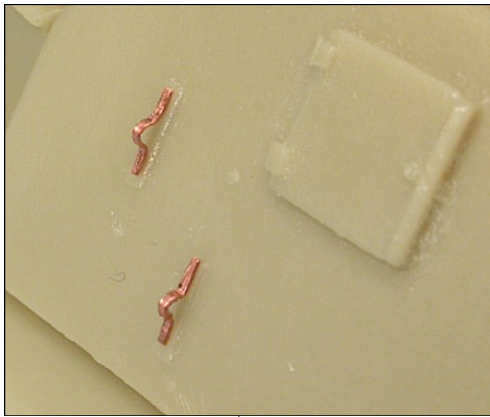

Forêt  
Drill  
ø 1 mm

B

A

Fil cuivre  
Copper rod  
ø 0.3mm

31

32

33

55

36

30

22

26

57

27

9

Épingle/pin

15

28

14

16

35



Aussi disponible / Also available



GAS50003  
Tracteur d'artillerie



GAS50144  
Version AA

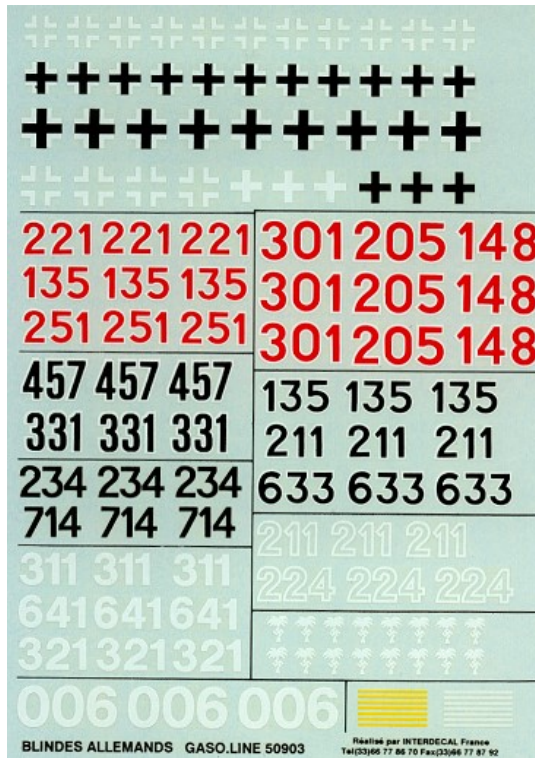

GAS50903

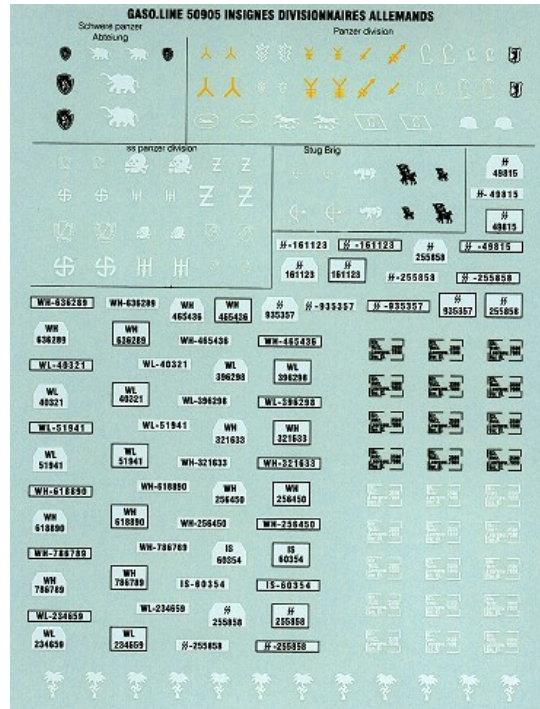

GAS50905

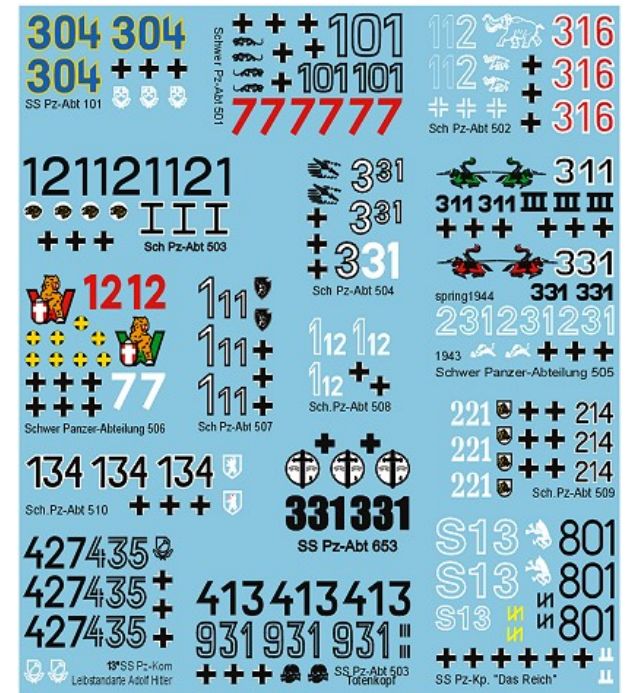

GAS50909 special Tigre I